



Specifications PRXMG5050+-V74

The PRXMG5050+-V74 is a Magellan 32-Zone Wireless Transceiver Control Panel.

Features:

- 2 serial outputs master/slave
- M2 two-way FSK hardware ready
- 8 on-board zones (16 with ATZ)
- Built-in transceiver (433 MHz)
- Expandable to 32 zones, 2 partitions, 32 users and 32 remotes
- 4-wire communication bus (connect up to 15 modules)
- Supports IP and cellular IP reporting
- Supports 16 PGMs (any of which can be wireless)
- App-based system control via BlueEye
- In-field firmware upgrade via 307USB And BabyWare remote or local
- Menu-driven programming for the Installer, Master and Maintenance codes
- Multiple telephone numbers for event reporting: 3 monitoring and 5 for Personal Dialing
- Calendar with Daylight savings Time
- StayD Mode
- Sleep arming method
- RF Jamming Supervision
- 512 events buffered.

P ▲ R ▲ D O X™



Specifications PRX278000033-P2C

The PRX278000033-P2C is a metal box enclosure for provision multiple module and panel mounting.

Features:

- Many punch-out holes for simple wiring
- Easy door removal
- Sizes: 28cm X 28cm X 7.6cm (11" x11" x 3")

P ▲ R ▲ D O X™



Specifications PRXK-TK278

The PRXK-TK278 is a BOM Kit for 1x tamper switch PRX2502302000-P2C and 1x tamper bracket PRX2781030000-P2C to suit with Paradox Metal Box Enclosure PRX2780000033-P2C; to protect against tampering (opening door or removal from wall).

P ▲ R ▲ D O X™

SP5500+ / SP6000+ / SP7000+ User Guide

4 to 32-Zone Expandable Security Systems



P ▲ R ▲ D O X™

NV5

High-Performance Digital Infrared Motion Detector

Description

The NV5 is the entry-level motion detector from Paradox's ENVY line of next generation motion detection. Featuring advanced processing technology, optical technology, and easy installation, the NV5 represents state of the art technology with the most advanced and innovative digital infrared detector of its class.

The NV5 features Paradox's developed optics - a Hybrid Cylindrical / Spherical combination 1.0 inch lens with 3rd generation 3D Lodiff® Fresnel segments- the first and most advanced lens in the detection industry. This combination offers the best detection possible for passive infrared energy reception optimized for far beams (cylindrical) and medium/close beams (spherical). This lens also features Paradox's "Equalized" detection pattern, ensuring equal sensitivity throughout the protected area. Furthermore, the NV5 offers Small Pet Resistance or, alternatively, a Super Creep Zone Mirror add-on optics, which provides superior detection directly below the detector (see Beam Pattern).

The NV5 offers Auto Pulse Signal Processing with two levels of RF rejection, dual or single edge processing, and LED feedback for each setting. With precision and equalized detection, superior detector stability, total area coverage, and complete false alarm protection, the NV5 is the most advanced and innovative digital infrared detector in its class.

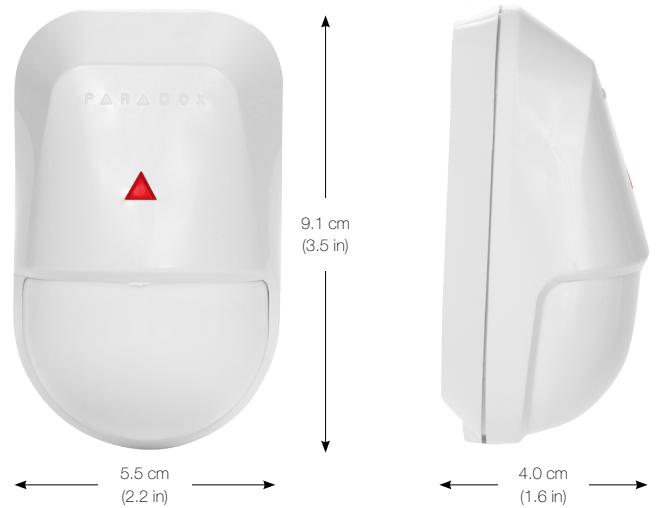

Features

- Infrared motion detector managed by Full Authority Digital Electronics Control (FADEC)
- Paradox's Hybrid Cylindrical-Spherical 1.0 inch lens with 3rd generation 3D Lodiff® Fresnel segments- 10 x 10 m (32.8 x 32.8 ft), 90° viewing angle, and 0.5 m (1.6 ft) to max range (no dead zone beam pattern)
- Paradox's equalized detection pattern - ensures equal sensitivity throughout the protected area
- Paradox Super Creep down-looking beam optic option for straight down detection
- Pet Resistance up to 16 kg (35 lb)
- Dual/Single Edge Processing selection - the only one in its class
- Paradox patented Auto Pulse Signal Processing (APSP) with settings for normal or high interference environments
- Digitally equalized temperature compensation; unit performance specifically tailored to obtain same catch capability at all specified operating temperatures
- Digital Sensitivity trimmer adjustment with five range levels and LED feedback, allows for perfect unit adjustment for all room sizes
- Optional wall/ceiling mount bracket
- Miniature yet easy to install with no PCB removal or adjustment
- CE and EN50131 Grade 2 approved (see PARADOX.com for latest approval updates)
- Interchangeable lenses; 90° standard lens

Advanced Digital Technology (FADEC)

The NV5's digital analysis and algorithms ensure precise and accurate detection performance, managed by Full Authority Digital Electronics Control (FADEC). Depending on the environment application, the NV5 can be easily configured with its unique pre-programmed profile settings (Normal, Moderate, Pet Resistant, and Harsh).

- High-resolution and full-dynamic range digital signal conversion
- High-speed, advanced algorithm, digital signal processing
- Digital EMI / RFI interference rejection
- Five choices of digital range levels (via trimpot)

Advanced Optical Technology

Paradox's Hybrid Cylindrical-Spherical combination offers the best detection possible for passive infrared energy reception for far beams (1. Cylindrical) and medium/close beams (2. Spherical). This lens design allows for ultimate perpendicular beam collection. Superior and uniform energy collection translates to a better image quality of the target which provides unmatched detection accuracy and stability.

- 3rd generation 3D LoDiff® Fresnel segments
- Optically and digitally equalized beam pattern (all beams optimized for generating equal signal level at any distance or angle)
- Optional Super Creep Zone or Pet Resistance up to 16 kg (35 lb)

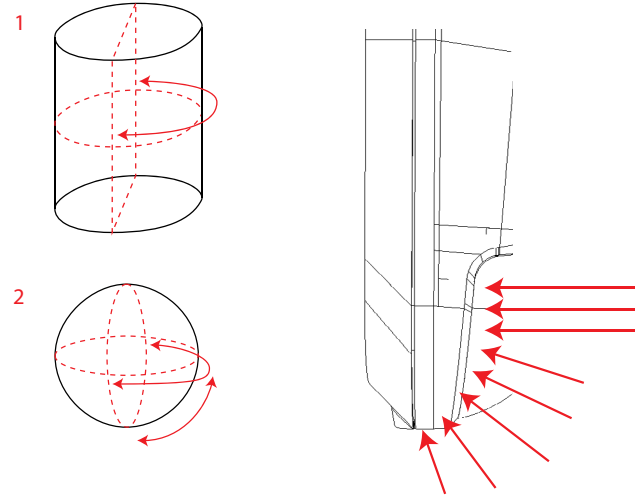

Technical Specifications

| | |
|-------------------------|--|
| Installation height | 2.1 m – 3.1 m (7.0 ft – 10.2 ft) For 10 m and above range, unit must be installed at 2.1 m (7.0 ft) height and above |
| Sensor | Dual rectangular element, low noise, high sensitivity, EMI immunity |
| Lens | Hybrid Cylindrical Spherical 3 rd gen. Fresnel Lens, equal beam sensitivity (patent pending) |
| Processing | High resolution digital signal processing. Four profiles (Normal, Medium, Pet Res., Harsh), true digital temperature compensation. |
| Super Creep Zone | Add on mirror option for enhanced creep zone at 0.1 m from the wall (no Pet Resistance) |
| Range adjustment | 5 level range adjustments (50% to 150%) |
| Startup time | 10 seconds |
| Detection speed | 0.2 m/s to 3 m/s (0.6 ft/s to 9.8 ft/s) |
| Power input | 10 Vdc to 15 Vdc |
| Current consumption | 10.5 mA @ Standby / 11.3 mA @ Alarm |
| Coverage | 10 m (32.8 ft) x 90° 0.5 m (1.6 ft) down looking with optional creep zone |
| PET Resistance | Up to 16 kg (35 lb) |
| Alarm indicator | Red LED for 3 seconds |
| Alarm output | Solid State, N.C. 150 mA |
| Anti-tamper switch | N.C. 28 Vdc, 0.15 A |
| Operating temperature | -10°C to 50°C (14°F to 122 °F) |
| Humidity | 95% max. |
| Dimensions | 9.1 x 5.5 x 4 cm (3.5 x 2.2 x 1.6 in.) |
| RFI Immunity | 10 V/m 80 MHz to 2 GHz |
| Environmental standards | Complies with EN 50131 Security Grade 2 / Environmental Class I |

Beam Pattern

TOP VIEW:

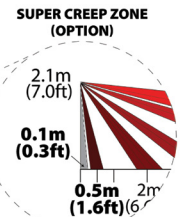
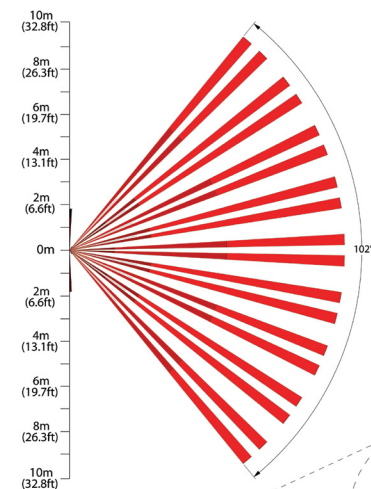

SIDE VIEW:

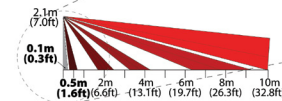

Wall/Ceiling Bracket

Wall Mount Bracket

Ceiling Mount Bracket



P ▲ R ▲ G D O X™

TM50 (5") / TM70 (7")

Touch Screen Keypads



TM50 / TM70

The TM50 / TM70 are touch screen input keypads designed to communicate with Paradox control panels, and offer user friendly interface. Both offer vivid colors and two sizes to select, 7" – TM70 or 5" – TM50.

The TM70 due to its larger screen allows for more information to be displayed on one screen and is more convenient in comparison to the TM50.

Both touch screen displays are compatible with Spectra, Magellan and EVO Paradox systems, and both support Paradox next generation Swan panels with RS-485 fast encrypted bus, and features like complete menu programming, remote keypad firmware upgrade and screen saver images download from the Insite GOLD application.

The TM70 / TM50 have screen savers with auto mode, adjustable brightness with auto dim mode and full dark sleep mode, indoor temperature display, bus voltage monitoring and easy multi-partition control.

The TM70 LCD color display resolution is 800 x 400 pixels while the TM50 resolution is 472 x 272 pixels. Both come with an external SD media card (4 GB), 2 GB free space for uploading jpegs for screen savers.

The TM70 is offered in white and the TM50 in white or black colors, other colors may be custom ordered.

Features

- ▶ 7" (TM70) / 5" (TM50) with vivid color display
- ▶ Compatible with Swan, EVO, Spectra and Magellan
- ▶ Built-in zone input
- ▶ Customizable labels (zones, partitions, users, doors and PGMs)
- ▶ External SD Media Card slot (4 GB with 2 GB of free space) for uploading photos; acts like a digital picture frame
- ▶ Firmware upgradable via SD card
- ▶ Indoor temperature reading
- ▶ In-wall bracket (optional)



TM70 installed with in-wall optional bracket

Technical Specifications

| | TM70 | TM50 |
|---------------------------|---|--|
| Power Input | 9 to 15 VDC | |
| Consumption | 250 mA at max brightness + 80 mA sounder | 150 mA at max brightness, +80 mA sounder |
| Wire Connection | 18 Gauge | 22 Gauge, 18 Gauge recommended |
| Display | 7" 800 x 480 | 5" 480 x 272 |
| Dimensions | 17.7 x 11.4 x 1.5 cm (7 x 4.5 x 0.6 in.) | 14.2 x 9.5 x 1.4 cm (5.6 x 3.75 x 0.56 in.) |
| Humidity | 5-90% | |
| Indoor Temperature | Yes | |
| SD Card | 4 GB; 2 GB free | |
| Input | Zone, configurable | |
| Tamper | Built-in, cover and wall | |
| Compatibility | Swan, EVO, Spectra, Magellan | |
| Remote Upgrade | Swan only | |
| Jpeg Download | Swan via Bus, EVO/Spectra SD Card | |
| Auto Dim | Yes | |
| Chime | Yes | |



P ▲ R ▲ D O X™

TTM70-G2K rev.04 - Printed in Canada 04/2019.
 Specifications may change without prior notice. US, Canadian and international patents may apply. Paradox is a trademark or registered trademark of Paradox Security Systems (Bahamas) Ltd. or its affiliates in Canada, the United States and/or other countries. © 2019 Paradox Security Systems Ltd. All rights reserved.



www.paradox.com



Specifications DFMSC03/CO/TOP

The DFMSC03/CO/TOP is the siren cover kit.

This siren cover kit comes with:

- UV treated plastic cover
- Combo Siren/Horn, 8 Ω /15W
- LED Strobe (Water-proof), 50mA
- Reed tamper switch
- Top hat piezo, 90mA @ 105dB
- 7-Way terminal block (pre-wired)

Total current draw for DFMSC03/CO/TOP is 590mA.

Operating voltage is 12VDC.

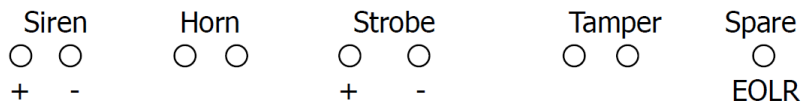



VRLA 12V7AH

SA12V7

Specifications

| | | |
|----------------------------------|--|-------------------------------|
| Nominal Voltage | 12 V | |
| Nominal Capacity 20HR | 7.0 AH | |
| Dimensions | Length | 151±1mm (5.94 inches) |
| | Width | 65±1mm (2.56 inches) |
| | Container Height | 95±1mm (3.74 inches) |
| | Total Height (with terminal) | 100±1mm (3.94 inches) |
| Approx Weight | Approx 2.10 kg (4.63 lbs) | |
| Terminal | F1 | |
| Container Material | ABS Plastic | |
| Lead Material | Purity Lead 99.995% | |
| Sulfuric Acid | Distilled Sulfuric Acid (Zero metal content) | |
| Separator | AGM | |
| Rated Capacity | 7.00 AH/0.350A | (20hr, 1.80V/cell, 25°C/77°F) |
| | 6.53 AH/0.653A | (10hr, 1.80V/cell, 25°C/77°F) |
| | 6.00 AH/1.20A | (5hr, 1.75V/cell, 25°C/77°F) |
| | 5.37 AH/1.79A | (3hr, 1.75V/cell, 25°C/77°F) |
| | 4.55 AH/4.55A | (1hr, 1.60V/cell, 25°C/77°F) |
| Max. Discharge Current | 105A (5s) | |
| Internal Resistance | Approx 23mΩ | |
| Operating Temp.Range | Discharge | : -15 - 50°C (5 - 122°F) |
| | Charge | : 0 - 40°C (32 - 104°F) |
| | Storage | : -15 - 40°C (5 - 104°F) |
| Nominal Operating Temp.Range | 25±3°C (77±5°F) | |
| Cycle Use | Initial Charging Current less than 2.1A. Voltage 14.4V - 14.7V at 25°C (77°F) Temp.Coefficient -30mV/°C | |
| Standby Use | No limit on Initial Charging Current Voltage 13.5V - 13.8V at 25°C (77°F) Temp.Coefficient -20 mV/°C | |
| Capacity affected by Temperature | 40°C (104°F) 103% 25°C (77°F) 100% 0°C (32°F) 86% | |
| Self Discharge | Sentry AGM series batteries may be stored for up to 6 months at 25°C (77°F) and then a freshening charge is required. For higher temperatures the time interval will be shorter. | |



Applications

- All purpose
- Standby Applications
- Recreation Vehicles
- Uninterruptible Power Supply (UPS)
- Electric Power System (EPS)
- Fire & Security
- Generators
- Medical Equipment

Dimensions

F1 Terminal

Unit: mm (inches)

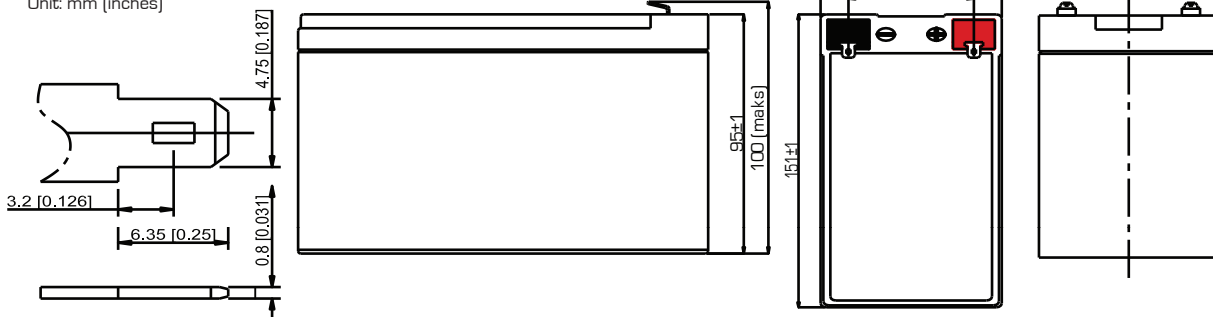

Constant Current Discharge (Amperes) at 25°C (77°F)

| F.V./Time | 5min | 10min | 15min | 20min | 30min | 45min | 1h | 2h | 3h | 4h | 5h | 6h | 8h | 10h | 20h |
|------------|------|-------|-------|-------|-------|-------|------|------|------|------|------|------|-------|-------|-------|
| 1.85V/cell | 18.0 | 12.8 | 10.48 | 8.79 | 6.53 | 4.79 | 3.86 | 2.29 | 1.69 | 1.36 | 1.14 | 0.98 | 0.774 | 0.640 | 0.345 |
| 1.80V/cell | 21.4 | 14.3 | 11.4 | 9.44 | 6.94 | 5.05 | 4.03 | 2.38 | 1.74 | 1.40 | 1.17 | 1.01 | 0.791 | 0.653 | 0.350 |
| 1.75V/cell | 24.2 | 15.6 | 12.2 | 10.0 | 7.29 | 5.27 | 4.18 | 2.45 | 1.79 | 1.43 | 1.20 | 1.03 | 0.805 | 0.663 | 0.357 |
| 1.70V/cell | 26.7 | 16.7 | 12.9 | 10.5 | 7.59 | 5.46 | 4.32 | 2.51 | 1.83 | 1.46 | 1.22 | 1.05 | 0.817 | 0.672 | 0.361 |
| 1.65V/cell | 28.8 | 17.7 | 13.5 | 10.9 | 7.86 | 5.62 | 4.46 | 2.57 | 1.86 | 1.48 | 1.23 | 1.06 | 0.826 | 0.680 | 0.365 |
| 1.60V/cell | 30.6 | 18.6 | 14.1 | 11.3 | 8.09 | 5.76 | 4.55 | 2.61 | 1.89 | 1.50 | 1.25 | 1.07 | 0.834 | 0.685 | 0.367 |

Constant Power Discharge (Watts/Cell) at 25°C (77°F)

| F.V./Time | 5min | 10min | 15min | 20min | 30min | 45min | 1h | 2h | 3h | 4h | 5h | 6h | 8h | 10h | 20h |
|------------|------|-------|-------|-------|-------|-------|------|------|------|------|------|------|-------|-------|-------|
| 1.85V/cell | 34.2 | 24.5 | 20.2 | 17.1 | 12.8 | 9.44 | 7.64 | 4.56 | 3.37 | 2.72 | 2.29 | 1.99 | 1.565 | 1.296 | 0.701 |
| 1.80V/cell | 40.2 | 27.2 | 21.9 | 18.3 | 13.5 | 9.91 | 7.96 | 4.72 | 3.47 | 2.79 | 2.34 | 2.03 | 1.593 | 1.318 | 0.708 |
| 1.75V/cell | 45.1 | 29.5 | 23.3 | 19.3 | 14.2 | 10.3 | 8.23 | 4.85 | 3.55 | 2.85 | 2.39 | 2.06 | 1.616 | 1.344 | 0.719 |
| 1.70V/cell | 49.2 | 31.3 | 24.5 | 20.1 | 14.7 | 10.6 | 8.48 | 4.96 | 3.62 | 2.89 | 2.42 | 2.09 | 1.633 | 1.347 | 0.725 |
| 1.65V/cell | 52.6 | 32.9 | 25.5 | 20.8 | 15.2 | 10.9 | 8.73 | 5.05 | 3.68 | 2.93 | 2.45 | 2.11 | 1.649 | 1.359 | 0.731 |
| 1.60V/cell | 55.5 | 34.3 | 26.3 | 21.5 | 15.5 | 11.2 | 8.88 | 5.12 | 3.72 | 2.96 | 2.47 | 2.13 | 1.660 | 1.367 | 0.734 |

Discharge Characteristics

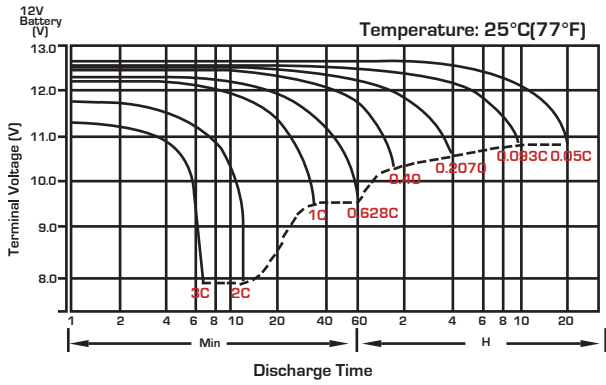

Float Charging Characteristics

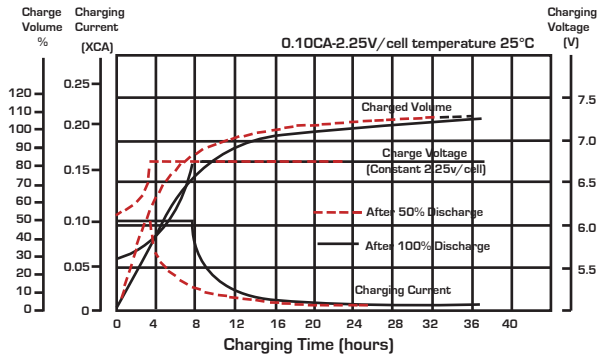

Temperature Effects in Relation to Battery Capacity

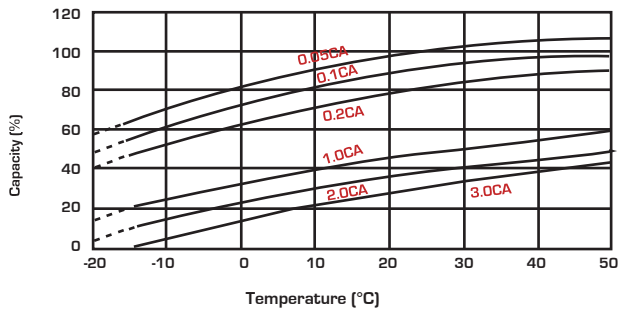

Effect of Temperature on Long Term Float Life

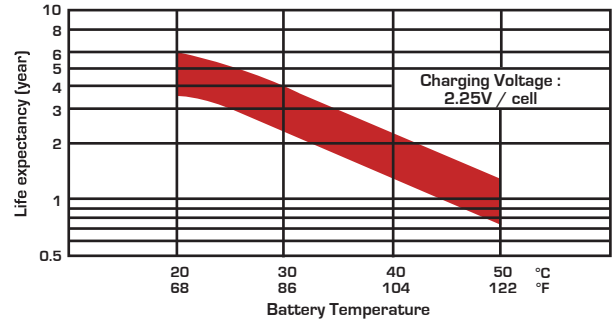

Cycle Life in Relation to Depth of Discharge

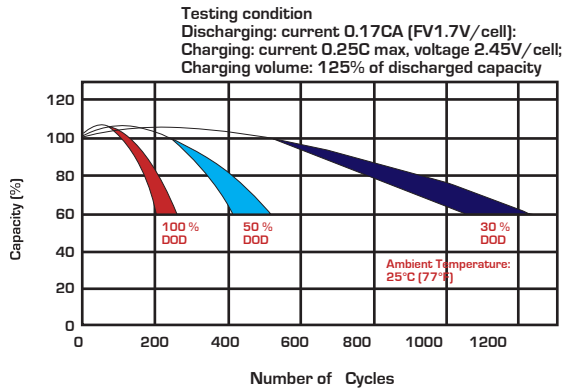

Self Discharge Characteristics

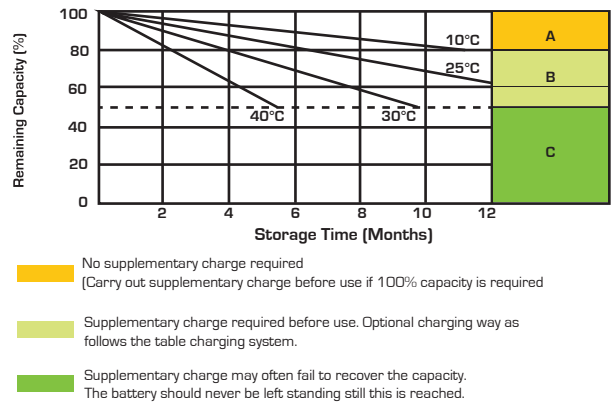

Charging System

| DOD | Current Limit (A) | Constant Voltage (V) | Fully Charged Time (h) |
|-----|---------------------|----------------------|------------------------|
| 20 | 0.15C ₁₀ | 13.5-13.8 vpc (12V) | 10 |
| | 0.20C ₁₀ | 6.75-6.9 vpc (6V) | 8 |
| 50 | 0.15C ₁₀ | 13.5-13.8 vpc (12V) | 15 |
| | 0.20C ₁₀ | 6.75-6.9 vpc (6V) | 12 |
| 80 | 0.15C ₁₀ | 13.5-13.8 vpc (12V) | 16 |
| | 0.20C ₁₀ | 6.75-6.9 vpc (6V) | 14 |
| 100 | 0.15C ₁₀ | 13.5-13.8 vpc (12V) | 20 |
| | 0.20C ₁₀ | 6.75-6.9 vpc (6V) | 18 |

State of Charge (SOC)

| Open Circuit Voltage (V/cell) | Open Circuit Voltage (12V/cell) | Open Circuit Voltage (6V/cell) | State of Charge (% of full charge capacity) |
|-------------------------------|---------------------------------|--------------------------------|---|
| 2.14-2.15 | 12.84-12.90 | 6.42-6.46 | 100 |
| 2.12-2.13 | 12.72-12.78 | 6.36-6.39 | 90 |
| 2.11 | 12.66 | 6.33 | 80 |
| 2.09 | 12.54 | 6.27 | 70 |
| 2.07 | 12.42 | 6.21 | 60 |
| 2.05 | 12.30 | 6.15 | 50 |



Sealed Performance Batteries

Domestic Sales | Ph: +61 (0)7 3386 1102 | Fax: +61 (0)7 3102 9913

sales@spb.net.au | www.sealedperformance.com.au

National Warehouse | 1 Ant Road | Yatala, Brisbane QLD 4207

Melbourne Office | 2/9 Compark Circuit | Mulgrave, Melbourne VIC 3170

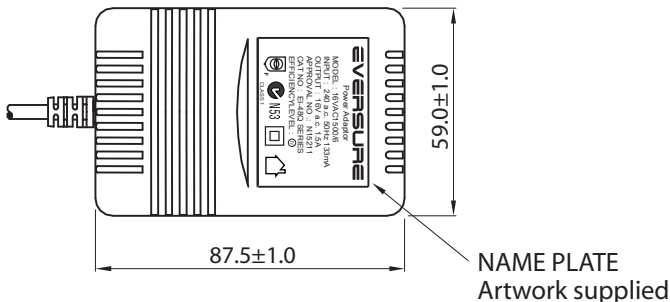
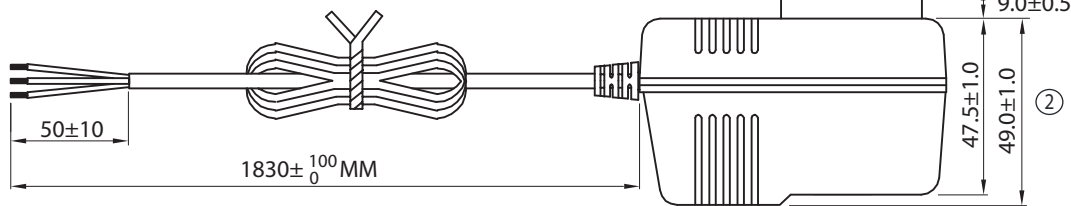
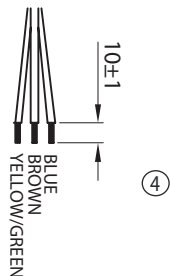

| | REVISED | DRAWN | APPROVED |
|---|--|----------------|--------------------|
| ① | AMENDED PACKING QTY AND CARTON SIZE | JACKY 10/08/09 | GARY 10/08/09 |
| ② | ADDED DATE CODE ON CASE AND DIMENSIONS | JACKY 07/12/09 | GARY 07/12/09 |
| ③ | ADDED PASSED LABEL ON CARTON | TODD 22/12/10 | JACKY 22/12/10 |
| ④ | AMENDED AC PINS DIMENSION & ADDED WIRES COLORS | ANLEI 01/11/12 | ANLEI 01/11/12 |
| ⑤ | CHANGED CROSS-SHAPED SCREW TO SHAPE SCREW ON CASE | MARK 31/08/15 | FREDERICK 31/08/15 |

- NOTES:
1. OUTPUT CORD: 20AWGX3C 1.83M Lead Free GREY (RAL7035)
 2. CASE: GREY (RAL7035)
 3. SECURITY SCREW IS AN ESSENTIAL REQUIREMENT, BOTH "" AND "" SHAPE ARE ACCEPTABLE

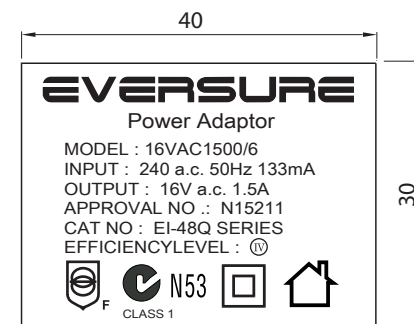

LABEL ARTWORK
Black word on Silver base label

| | | | | | | | | | | |
|--|-----|-------|----------|----------|-------------------------|-------|--------------|------|--------------|--|
| TE DRAWING NO: TE40-0001 R5 | | | | | PART NO: 16VAC1500MPS/6 | | | | | |
| DESCRIPTION: AC ADAPTOR EI-48Q, 16VAC1500mA, 3 WIRE - MEPS | | | | | | | | | | |
| SIZE | A4 | DATE | 30/04/09 | CHECKED | KEVIN 30/04/09 | | ORDER REF: | 0420 | SHEET 1 OF 3 | TOLERANCES UNLESS OTHERWISE STATED X.= +/- .X.= +/-0.5 .XX.= +/-0.2 |
| UNIT | MM | DRAWN | KEVIN | APPROVED | FRANK 30/04/09 | | CUSTOMER: TE | | | |
| SCALE | NTS | MANU: | | | | DATE: | | | | |



THIS DRAWING AND SPECIFICATIONS ARE THE PROPERTY OF TELEPHONE EQUIPMENT (NSW) Pty Ltd AND SHALL NOT BE REPRODUCED OR USED IN ANY MANNER WITHOUT THE PRIOR WRITTEN CONSENT OF TELEPHONE EQUIPMENT (NSW) Pty Ltd

| ITEM | SPECIFICATION | |
|---|---|--|
| 1. Primary rated input voltage | AC240V 50Hz 133mA | |
| 2. Secondary rated output voltage and current | Unloaded voltage: AC 18 V ± 5% Loaded Voltage : AC 16 V ± 5% AT 1500 mA | |
| 3. Ripple voltage | *** mV (RMS) MAX. AT Rated Loading | |
| 4. Insulation resistance | Primary - secondary: DC 500 V 100 MΩ Min | |
| 5. Dielectric withstand test | Primary - secondary: AC 3.64 KV 1 seconds | |
| 6. Temperature rise | At rated loading 90°C max. For input coil (By resistance method) and 55°C max. on case surface (By use of thermometer) | |
| 7. EFFICIENCY | ≥ 79% | |
| 8. Leadout | Primary | SAA PLUG IN TYPE |
| | Secondary | PVC cable length: 1.8 Meter Colour : GREY (RAL7035) Wire size: AWG#20/3C Plug : STRIPPED AND TINNED |
| 9. Test circuit | <p>The diagram shows a transformer with a thermal fuse on the primary side. The secondary side is connected to a load circuit containing an ammeter (A), a voltmeter (V), and a variable load resistor.</p> | |
| 10. Case | SAA48 colour = GREY (RAL7035) | |

| | REVISED | DRAWN | APPROVED |
|---|--|----------------|--------------------|
| ① | AMENDED PACKING QTY AND CARTON SIZE | JACKY 10/08/09 | GARY 10/08/09 |
| ② | ADDED DATE CODE ON CASE AND DIMENSIONS | JACKY 07/12/09 | GARY 07/12/09 |
| ③ | ADDED PASSED LABEL ON CARTON | TODD 22/12/10 | JACKY 22/12/10 |
| ④ | AMENDED AC PINS DIMENSION & ADDED WIRES COLORS | ANLEI 01/11/12 | ANLEI 01/11/12 |
| ⑤ | CHANGED CROSS-SHAPED SCREW TO SHAPE SCREW ON CASE | MARK 31/08/15 | FREDERICK 31/08/15 |

TE DRAWING NO: TE40-0001 R5

PART NO: 16VAC1500MPS/6

DESCRIPTION: AC ADAPTOR EI-48Q, 16VAC1500mA, 3 WIRE - MEPS



THIS DRAWING AND SPECIFICATIONS ARE THE PROPERTY OF TELEPHONE EQUIPMENT (NSW) Pty Ltd AND SHALL NOT BE REPRODUCED OR USED IN ANY MANNER WITHOUT THE PRIOR WRITTEN CONSENT OF TELEPHONE EQUIPMENT (NSW) Pty Ltd

| | | | | | | | | | | |
|-------|-----|-------|----------|----------|----------------|-------|------------|------|--------------|--|
| SIZE | A4 | DATE | 30/04/09 | CHECKED | KEVIN 30/04/09 | | ORDER REF: | 0420 | SHEET 2 OF 3 | TOLERANCES UNLESS OTHERWISE STATED X.= +/- .X.= +/-0.5 .XX.= +/-0.2 |
| UNIT | MM | DRAWN | KEVIN | APPROVED | FRANK 30/04/09 | | CUSTOMER: | TE | | |
| SCALE | NTS | MANU: | | | | DATE: | | | | |

| | REVISED | DRAWN | APPROVED |
|---|--|-------------------|-----------------------|
| ① | AMENDED PACKING QTY AND CARTON SIZE | JACKY 10/08/09 | GARY 10/08/09 |
| ② | ADDED DATE CODE ON CASE AND DIMENSIONS | JACKY 07/12/09 | GARY 07/12/09 |
| ③ | ADDED PASSED LABEL ON CARTON | TODD 22/12/10 | JACKY 22/12/10 |
| ④ | AMENDED AC PINS DIMENSION & ADDED WIRES COLORS | ANLEI 01/11/12 | ANLEI 01/11/12 |
| ⑤ | CHANGED CROSS-SHAPPED SCREW TO SHAPE  SCREW ON CASE | MARK 31/08/15 | FREDERICK 31/08/15 |

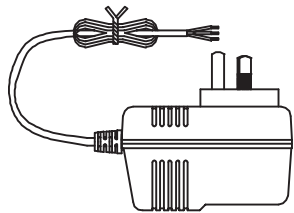

1 PC/WHITE BOX

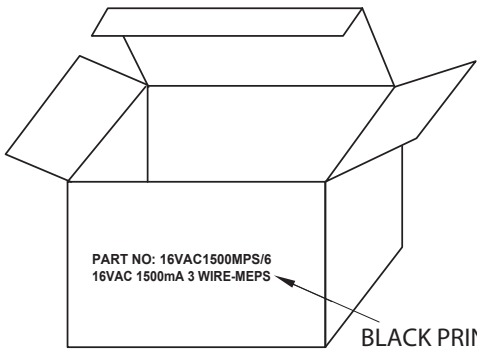

PART NO: 16VAC1500MPS/6
16VAC 1500mA 3 WIRE-MEPS

BLACK PRINTING

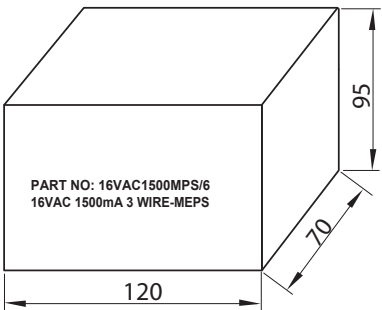

20 BOXES/CARTON ①

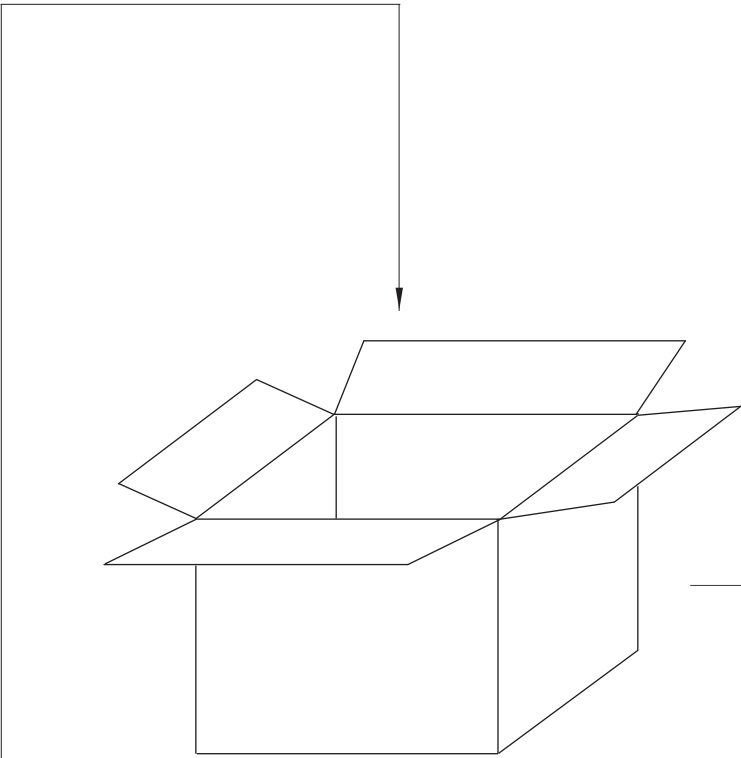

SHIPPING CARTON
PLEASE FOLLOW ORDER TO PRINT SHIPPING MARKS.

ADHESIVE TAPE

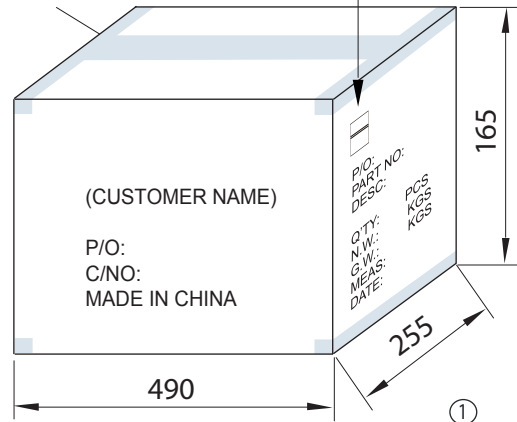

ONLY ONE RoHS+PASSED LABEL ON CARTON
RoHS LABEL(5X25MM)
GREEN GROUNDING YELLOW TEXT
PASSED LABEL(5X36MM)
BLUE GROUNDING WHITE TEXT
WHITE GROUNDING BLUE TEXT

TE DRAWING NO: TE40-0001 R5 PART NO: 16VAC1500MPS/6

DESCRIPTION: AC ADAPTOR EI-48Q,16VAC1500mA, 3 WIRE - MEPS



THIS DRAWING AND SPECIFICATIONS ARE THE PROPERTY OF TELEPHONE EQUIPMENT (NSW) Pty Ltd AND SHALL NOT BE REPRODUCED OR USED IN ANY MANNER WITHOUT THE PRIOR WRITTEN CONSENT OF TELEPHONE EQUIPMENT (NSW) Pty Ltd

| | | | | | | | | | | |
|-------|-----|-------|----------|----------|-------------------|---|------------|------|--------------|---|
| SIZE | A4 | DATE | 30/04/09 | CHECKED | KEVIN 30/04/09 |  | ORDER REF: | 0420 | SHEET 3 OF 3 | TOLERANCES UNLESS OTHERWISE STATED X.= +/-1 .X.= +/-0.5 .XX.= +/-0.2 |
| UNIT | MM | DRAWN | KEVIN | APPROVED | FRANK 30/04/09 | | CUSTOMER: | TE | | |
| SCALE | NTS | MANU: | | | | | DATE: | | | |



Specifications TELLC0280

The TELLC0280 is the telephone lead with 606 Socket and 2 Meter length of Telephone Cord.

Colour: Ivory.

