

# Power Distribution Board with Battery Charger

## Features

- Reverse Polarity Battery Protection
- Multiple Fused Outputs
- Low battery and Supply Fail Contacts
- 1.2A Linear Battery Charger

## Layout

1. Output Terminal Blocks
2. Individual Circuit LED
3. Individual Circuit Fuses (1A Each)
4. Battery Charger (1.2A)
5. Low Battery Terminal (NC/NO)
6. Input Terminal (10V-16VDC)
7. Mains Fail Terminal (NC/NO)
8. Main Fuse
9. High Current Terminal (Max Current Supplied)

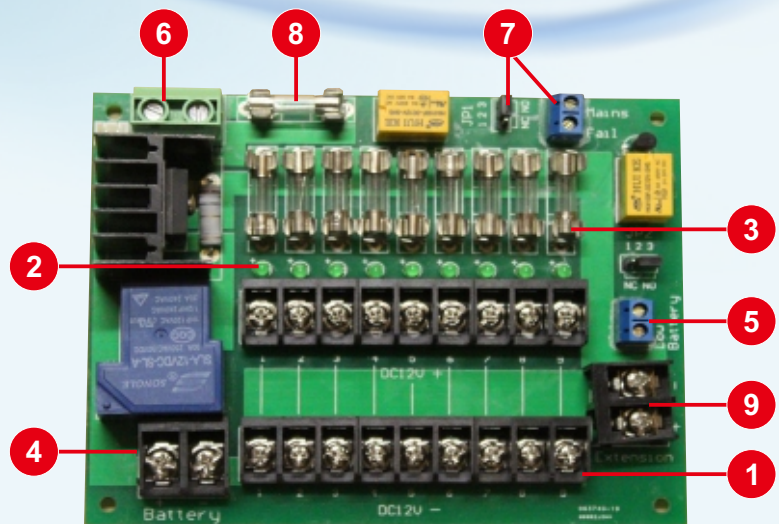

9 Way

## Applications



## Specifications

DC Type	4 Way	9 Way	16 Way
Model	ZP-DC-4WAY-PCB	ZP-DC-9WAY-PCB	ZP-DC-16WAY-PCB
Input Voltage	10V - 16V DC		
Output	4 x fused outputs	9 x fused outputs	16 x fused outputs
Total Current	4A Max.	9A Max.	16A Max.
Relay Rating	1A 30VDC		
Size(LxWxH)	133 x 106 x 31mm	133 x 106 x 31mm	190 x 106 x 31mm
Weight	170g	180g	220g



# Power Distribution Board

## Features

- Multiple Output Boards
- Total Current Fuse
- Multiple 1A Outputs

## Layout

1. Output Terminal Blocks
2. Individual Circuit LED
3. Individual Circuit Fuses (1A Each)
4. Input Terminal (10V-30V DC/AC)
5. Main Fuse
6. High Current Terminal (Max Current Supplied)

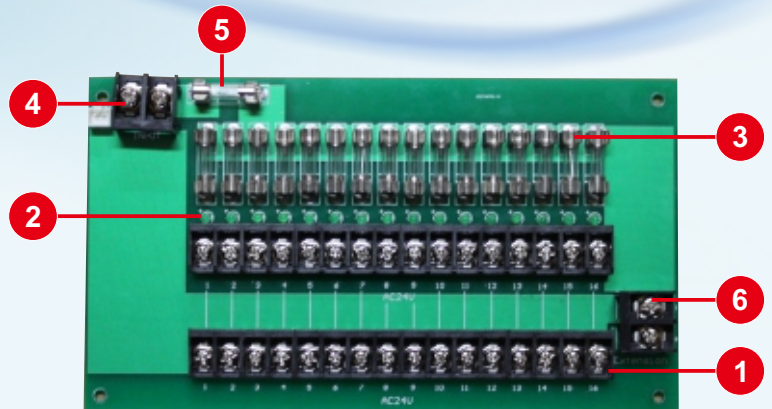

**16 Way**

## Applications

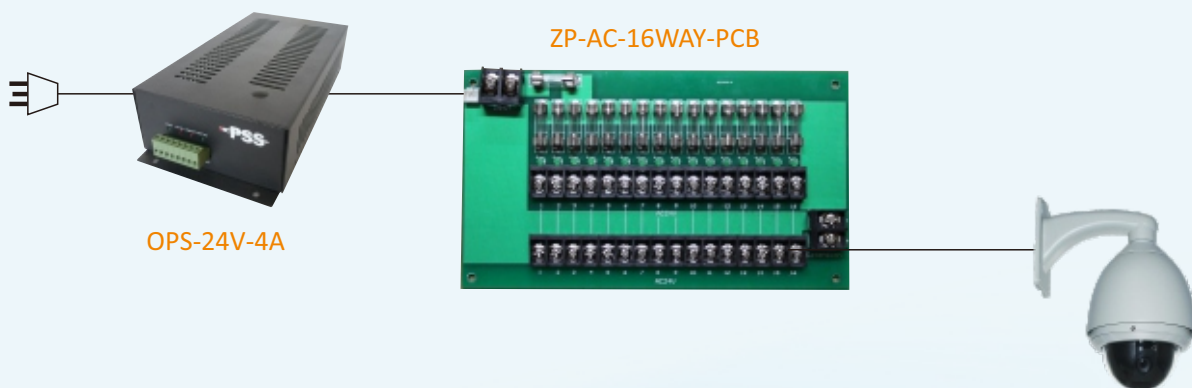

## Specifications

AC Type	9 Way	16 Way
Model	ZP-AC-9WAY-PCB	ZP-AC-16WAY-PCB
Input Voltage	10V-30VDC/AC	
Output	9 x fused outputs	16 x fused outputs
Total Current	9A Max.	16A Max.
Relay Rating	1A 30VDC	
Size(LxWxH)	133 x 106 x 15mm	190 x 106 x 15mm
Weight	180g	200g

